

Datasheet

Napo



Product Description

Napo is a small, elegant luminaire perfect for adding accent lighting to any area.

Specification Text

The luminaire shall be manufactured from high-pressure die-cast aluminium. It shall have an LED efficacy of up to 50 lm/W and will be capable of producing up to 250 luminaire lumens at 4000K with a CRI >80. It shall have an asymmetric forward throw optic and is rated at IP66 and IK07.

Specification

Weight: 0.3kg
 Material: Die-cast Aluminium
 Paint finish: Graphite Grey Finish

Optics

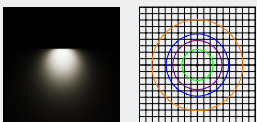

Very Wide Flood 80°

Key Features



- 5.0W
- 250 Luminaire Lumens
- Efficacy up to 50 lm/W
- 4000K, CRI >80
- Lifetime >60000hr, L80



Dimensions

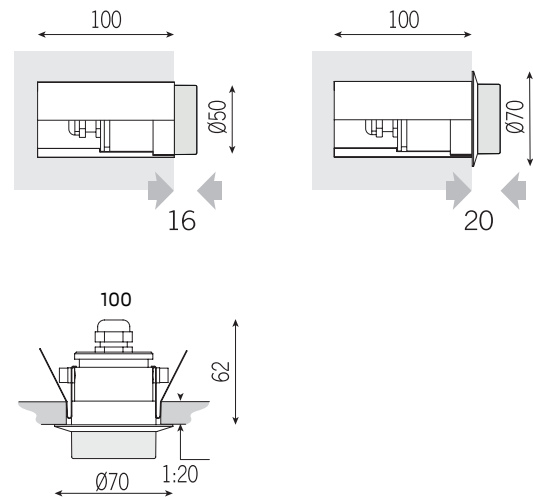

All units of measurement in mm.

Code	Power	Luminaire Lumens	Optic	CCT(K)	IP	IK	Weight kg	Paint Finish	Driver Included
NAP-SY80-830-5-16	5.0	250	Very Wide Flood 80°	3000	IP66	IK07	0.3	Graphite Grey Finish	Driver inc
NAP-SY80-840-5-16	5.0	250		4000	IP66	IK07	0.3	Graphite Grey Finish	Driver inc



Accessories & Options

Mounting Options

- Ceiling and Wall Mount
[Contact for details](#)

Other Options

- Colour Temperature Options
- Paint Finish Options
[Contact for details](#)